

SHARKSET SUSPENSION KIT INSTALLATION MANUAL

SHARKSET MOBILITY[®]

WWW.SHARKSET.COM

SALES@SHARKSET.COM

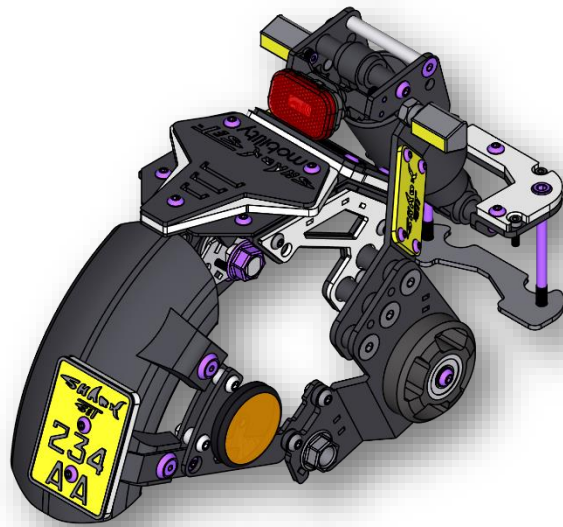

Version 2.0

JUN, 8, 2022

Dear Customer!

Thank You for Purchasing SHARKSET Suspension Kit. This manual visually presents how your suspension kit should be assembled. You will need to hand tighten all screws & add thread locking glue (E.g. Loctite sold separately) to all screws before use. Recheck all screws and nuts after your first ride to make sure they are secured in place. These should be rechecked periodically as routine maintenance.

In this package you will find:

- Suspension Kit
- Necessary Tools
- Plastic Fender
- Brake Light
- Extra Bracket to Hold Mudguard (only in some production batches)

(Turn Signal Lights Are Sold Separately)

We strongly recommend you to watch our official installation video published on SHARKSET YouTube Channel or join our Facebook Group to stay connected with us.

YOUTUBE.COM/SHARKSET

FACEBOOK.COM/SHARKSETOFFICIAL

In this printed manual, we aim to present an installation map and make you familiar with different types of screws that should be used in the installation process.

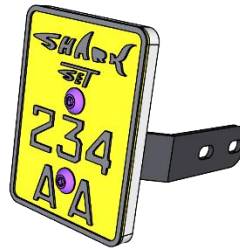

Figure 1 License Plate Front View



Figure 2 License Plate Back View

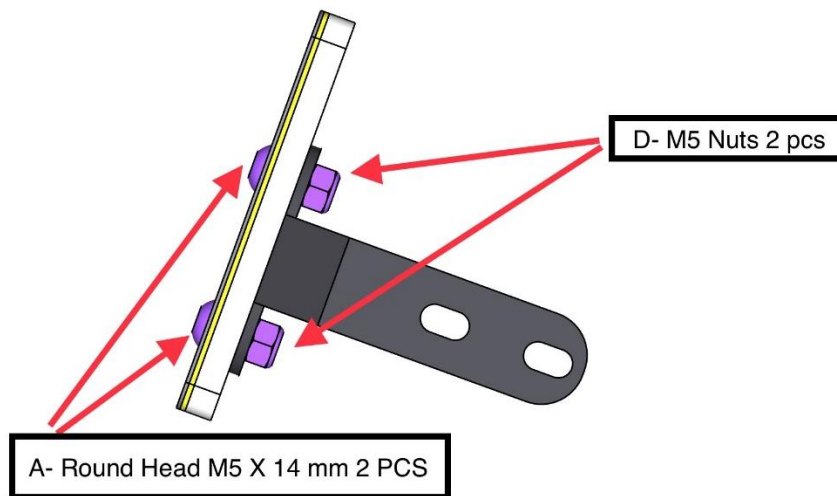

Figure 3 License Plate Screws/Nuts

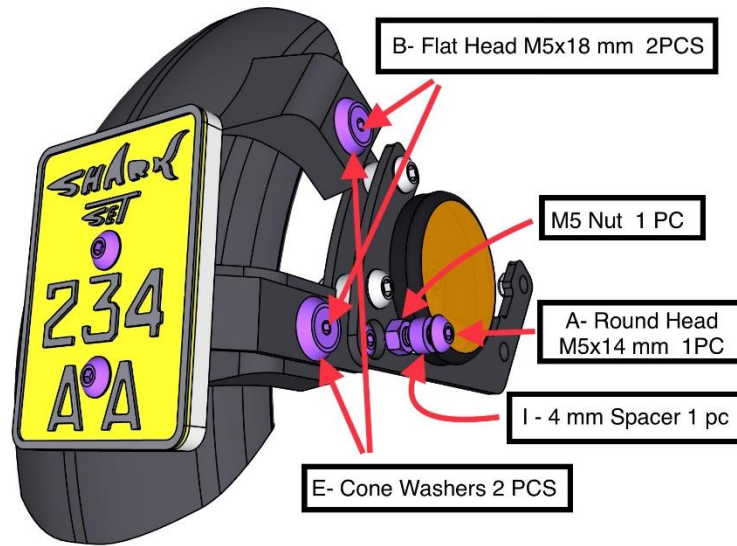

Figure 4 Rear Mudguard to Swing Arm Connection

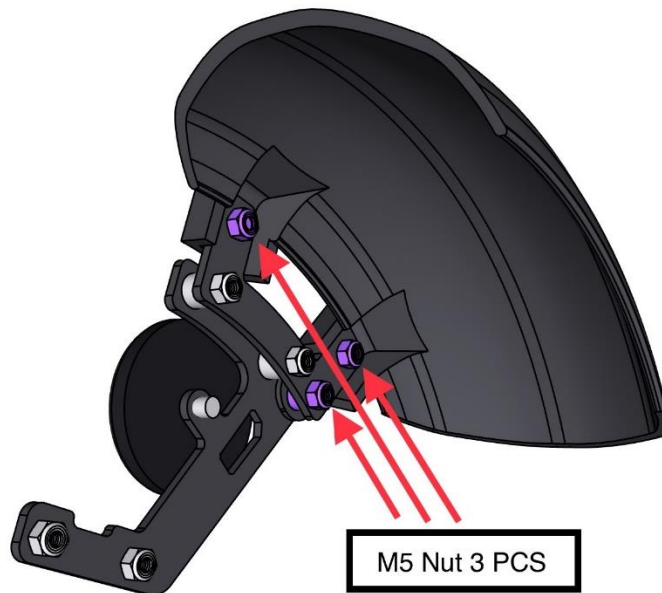

Figure 5 Rear Mudguard to Swing Arm Connection



Figure 6 Metal Mudguard (3D view)

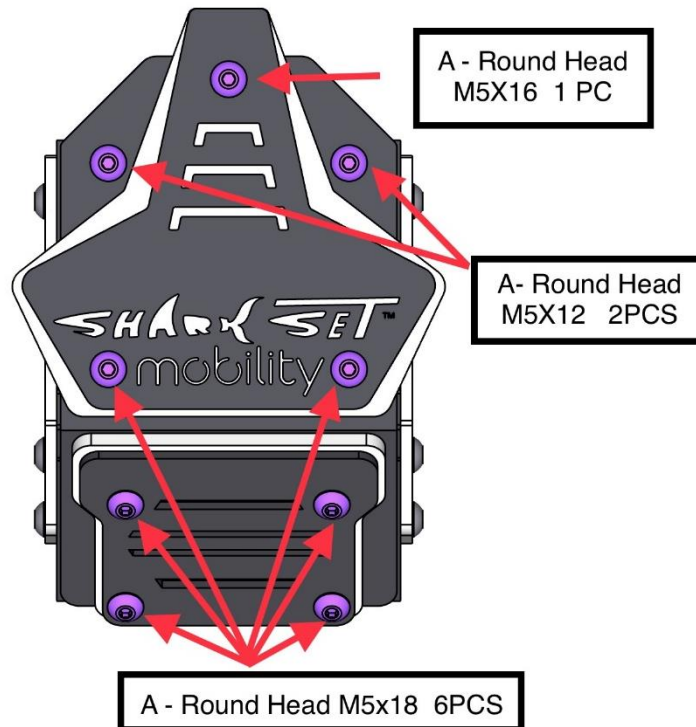

Figure 7 Metal Mudguard and Acrylic Covers (Top View)

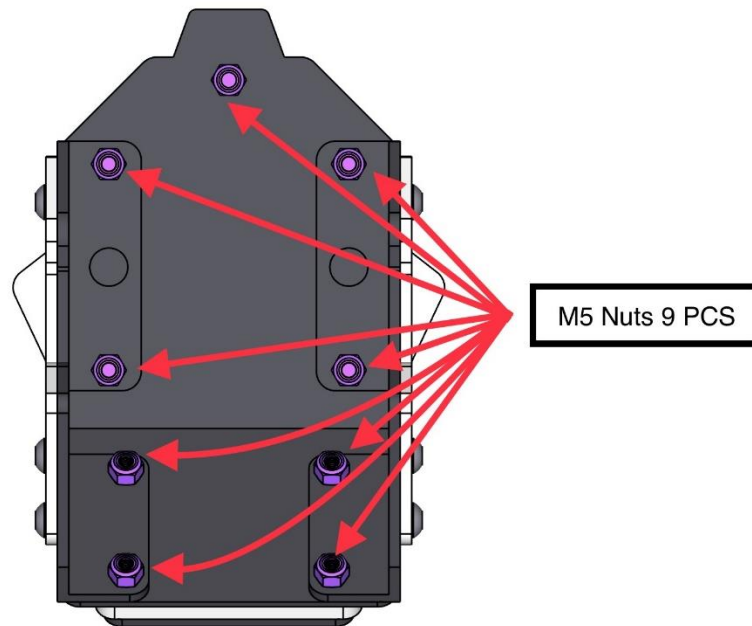

Figure 8 Metal Mudguard and Acrylic Covers (Underneath View)

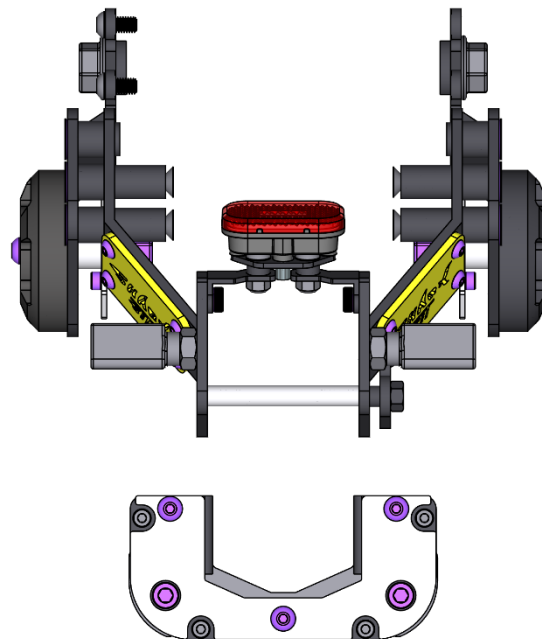

Figure 9 Brake Light to Swing Arm (Top View)

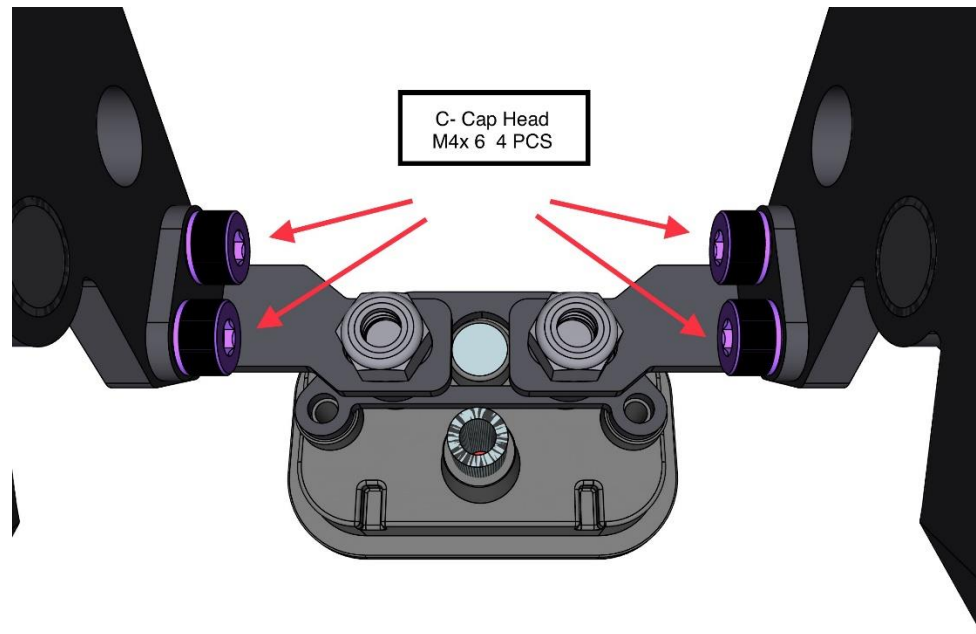

Figure 10 Brake Light to The Swing Arm Connection (Back View)

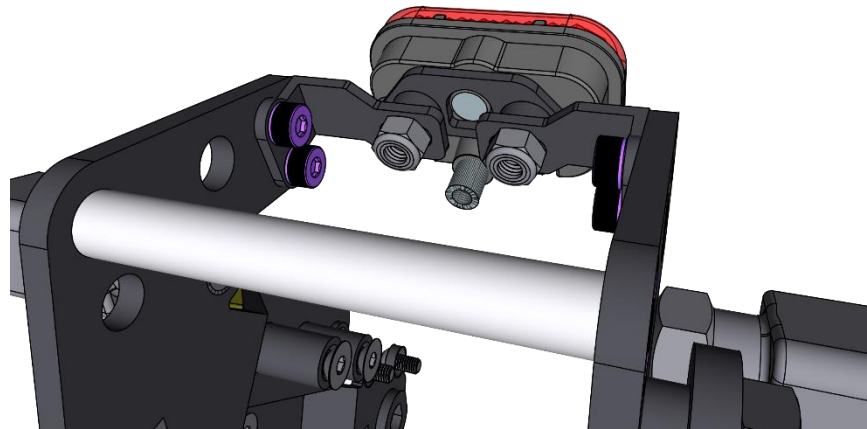

Figure 11 Brake Light to Swing Arm Connection (Back View)

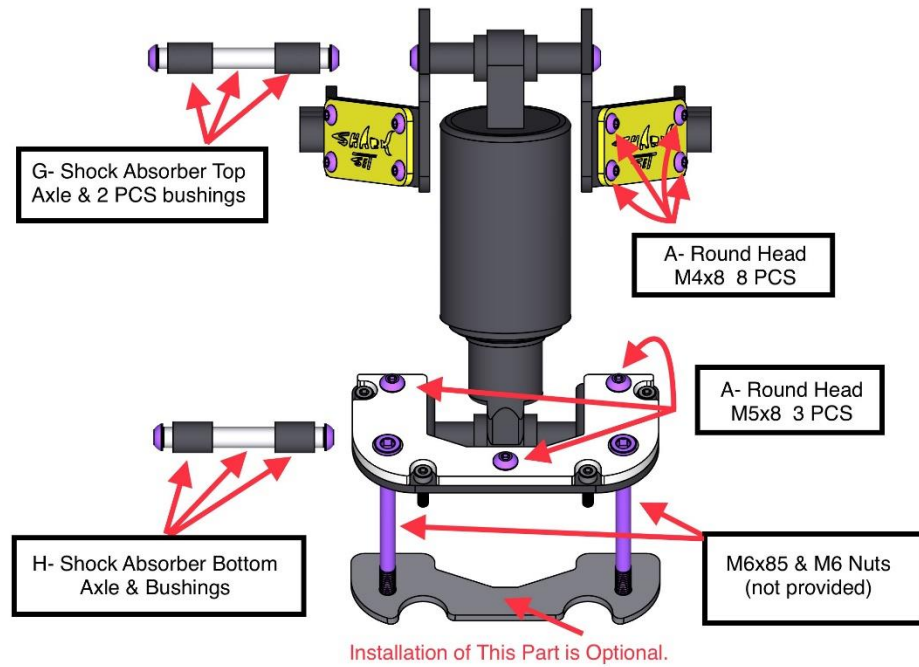

Figure 12 Shock Absorber to Swing Arm Connection (Front View)

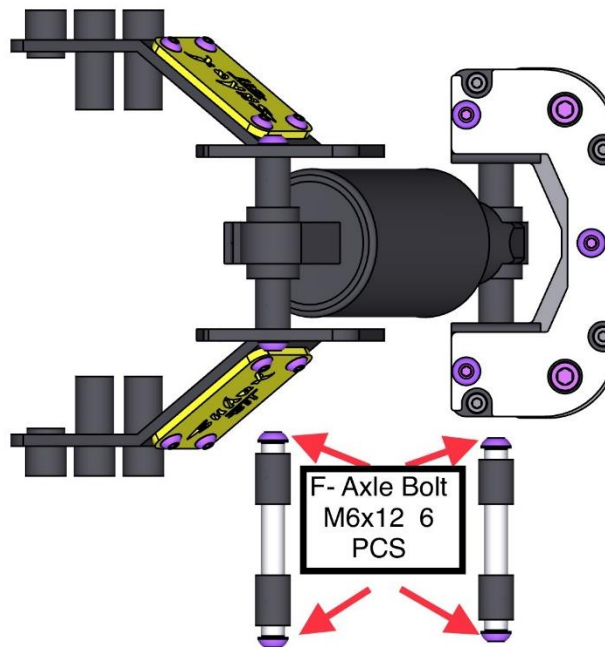

Figure 13 Shock Absorber to Swing Arm Top View (Axle Bolts)

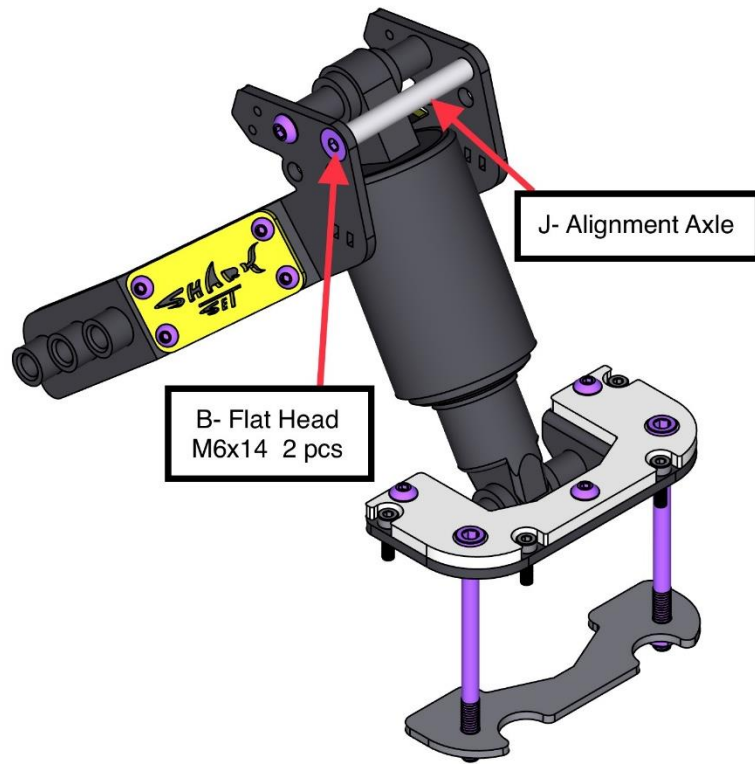

Figure 14 Shock Absorber to Swing Arm (Alignment Axle & Screws- Side View)

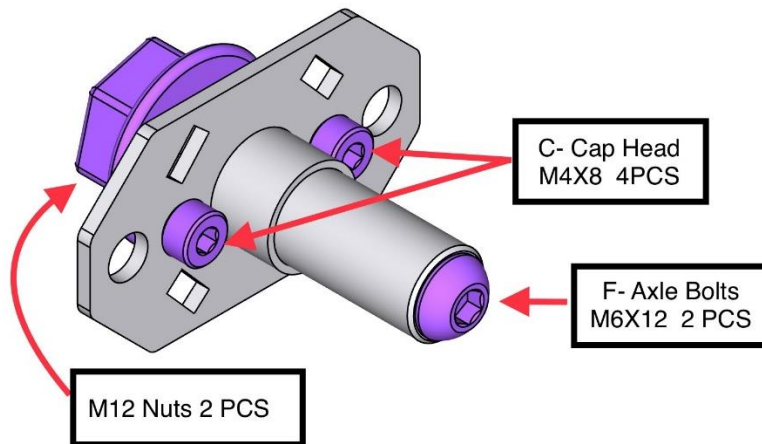

Figure 15 Special Stainless Steel Axle that Links Swing Arms to Frame

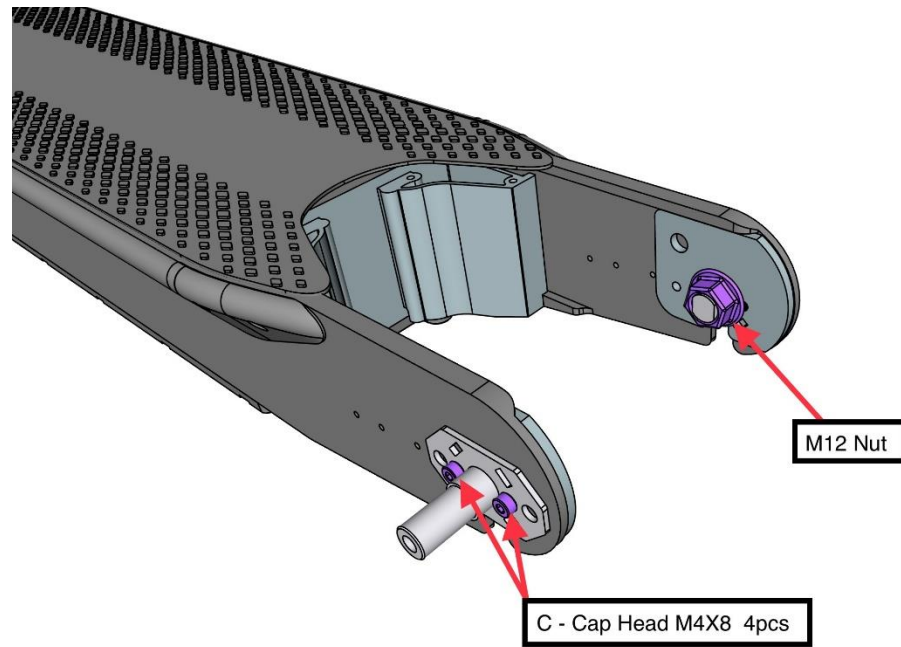

Figure 16 connecting axles to frame (Hand tight the screws first then tight the nuts as tight as possible)

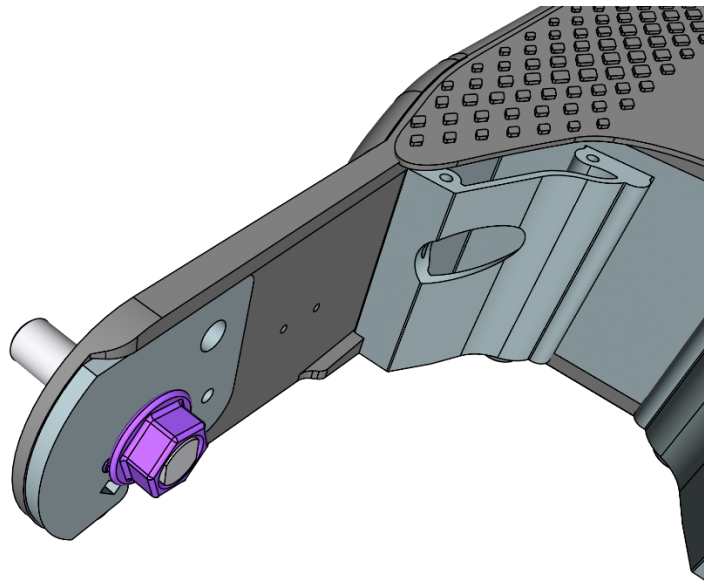

Figure 17 Connecting the axle to the frame

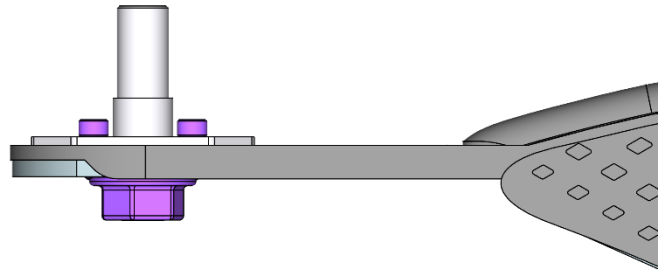

Figure 18 connecting axle to frame

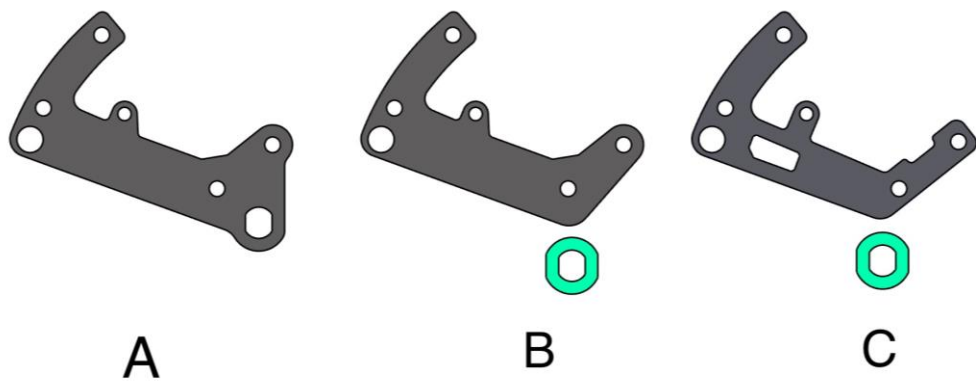

Figure 19 Mudguard holding bracket

Important Note: SHARKSET Rear Suspension comes with three types of mudguard holders depending upon production batch as shown above. Kindly study Table 1 and follow the instruction shown in Table 1.

MUDGUARD HOLDER INSTALLAION MANUAL	MY DEFULT MUDGUARD HOLDER IS LIKE TYPE A	MY DEFULT MUDGUARD HOLDER IS LIKE TYPE B	MY DEFULT MUDGUARD HOLDER IS LIKE TYPE C
NEED TO INSTALL ONE 4MM WASHER ON THE LEFT SIDE OF MOTOR?	YES	YES	YES
NEED TO INSTALL ONE 4MM WASHER ON THE RIGHT SIDE OF MOTOR?	NO	YES	YES
NEED TO UPGRADE?	NO	NO	UPGRAED TO TYPE A OR B

Table 1: MUDGUARD & WASHER INSTALLATION MANUAL

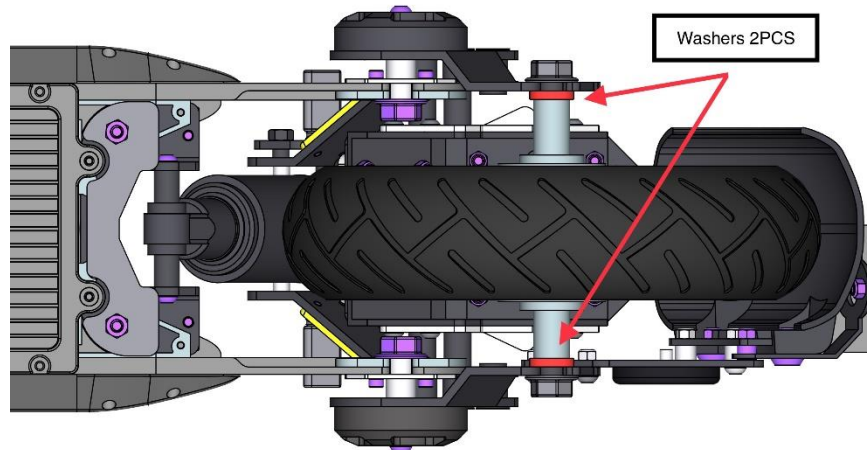
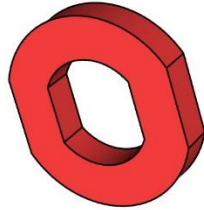

Figure 20 Installing Torque Washers (find them in toolbox)



Washers 2pcs : Find them in tool box

Figure 21 Washers (*in some production batches only one washer is provided- kindly refer to the picture 19*)

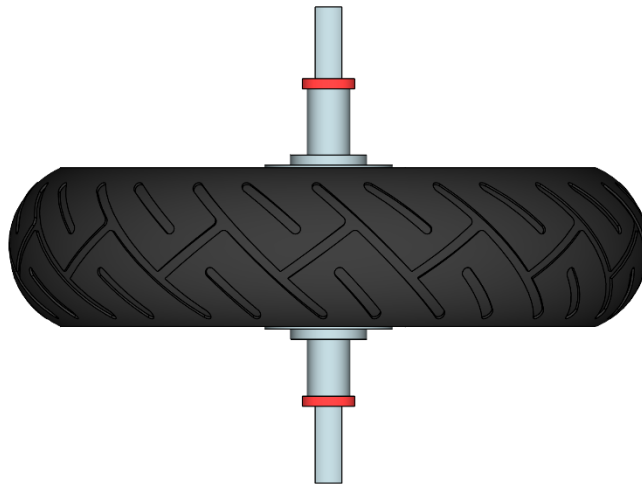

Figure 22 Washers Should be Placed between Motor and Swing Arms

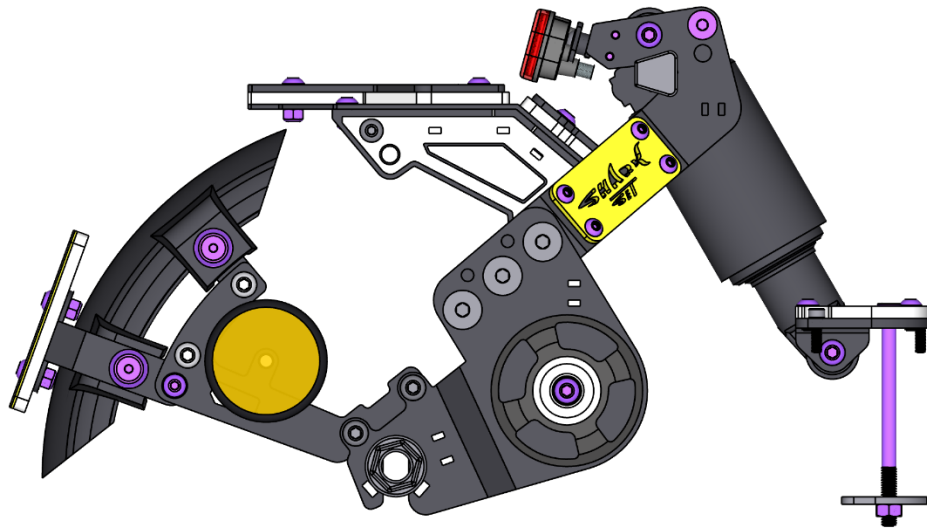

Figure 23 A Fully Assembled Kit (Side View)

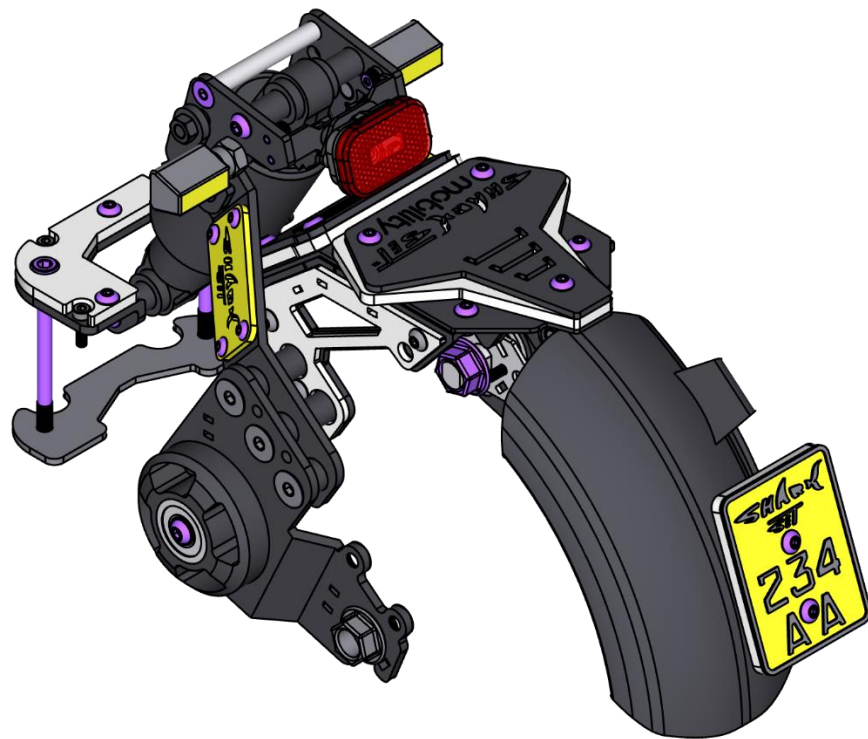

Figure 24 A Fully Assembled Suspension Kit

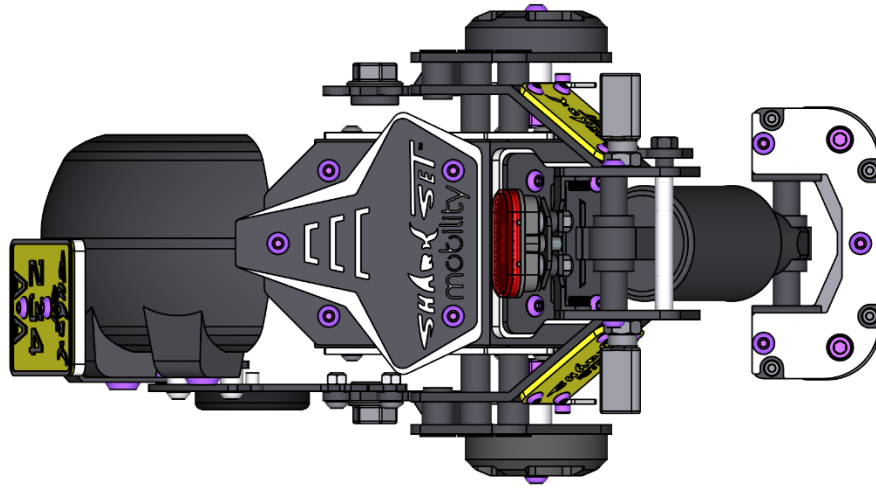

Figure 25 A Fully Assembled Suspension Module (top View)

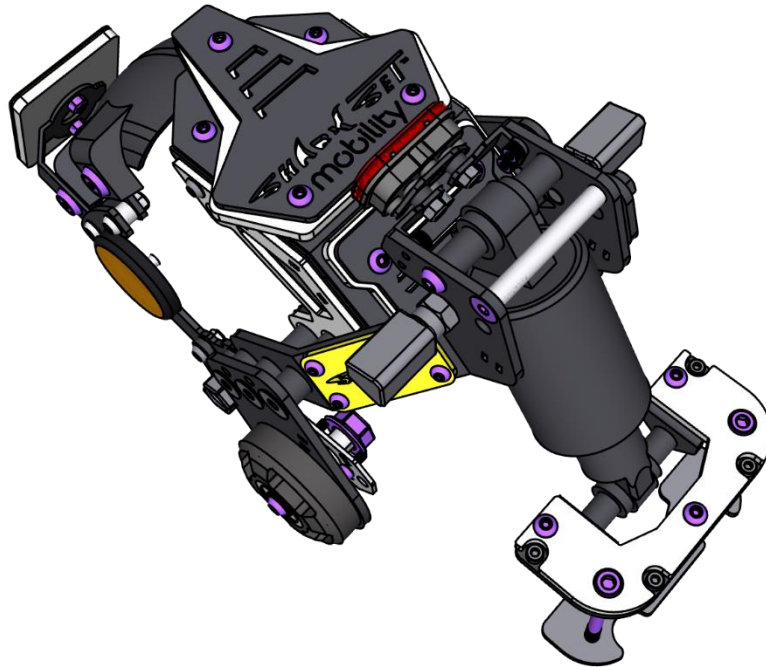

Figure 26 A Fully Assembled Rear Suspension Module

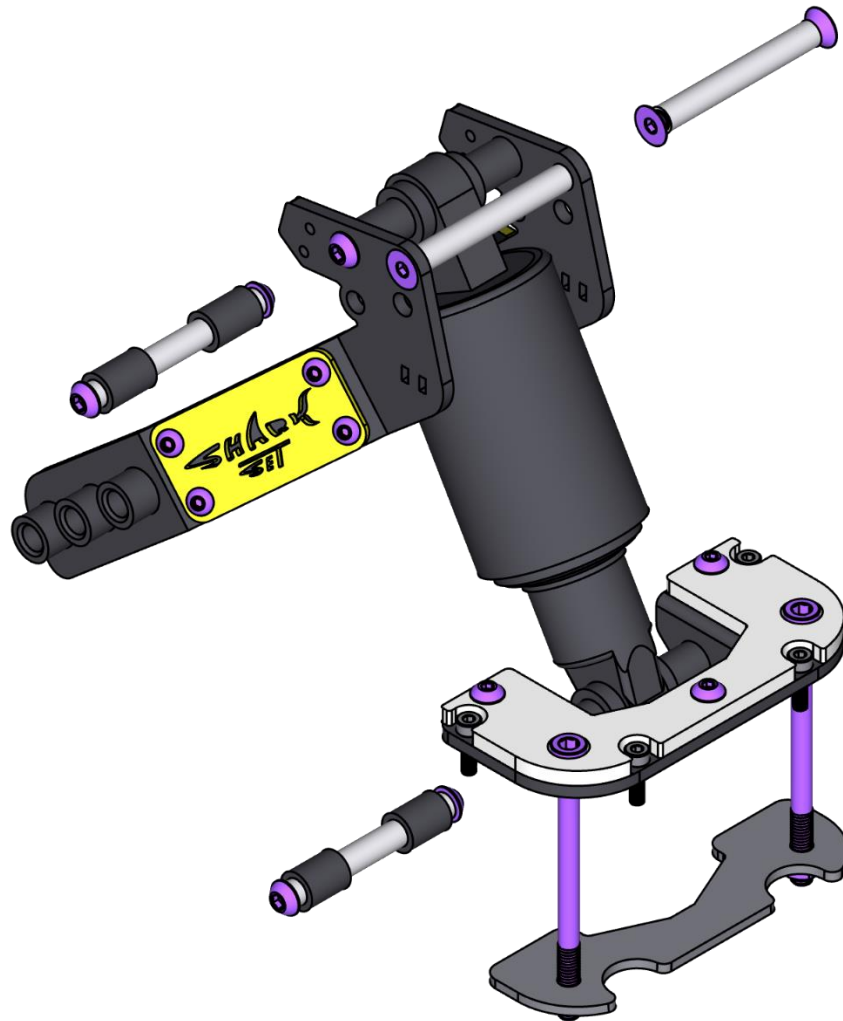

Figure 27 Axles and Bushings & Alignment Axle

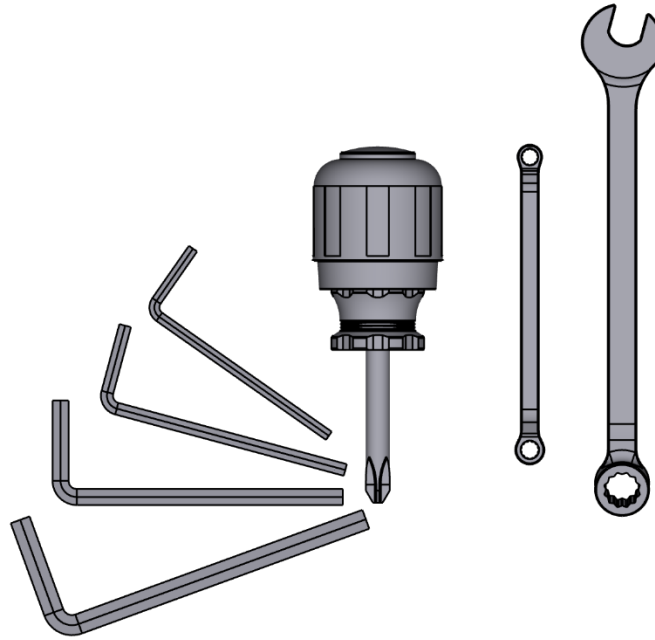

Figure 28 Tools Provided (Actual Tools May Differ From The Above Photo)